

grazia&co melbourne  
1 / 10-14 advantage road  
highett, vic, 3190  
phone +61 3 9555 5760

grazia&co sydney  
12b, 32 ralph street  
alexandria, nsw, 2015  
phone +61 2 8914 0350

## featherston hob range



designed by mary featherston, the hob range is made from a solid american ash timber frame. the vegetable dyed saddle leather features a craftsman bonded thread topstitch detail with solid brass buckles to the underside of the wrapped seat and chair backrest. (c1972).

grazia&co<sup>®</sup>

timber



black



frost

saddle leather



black



natural

buckle



natural brass



# technical specifications

---

1 - chair

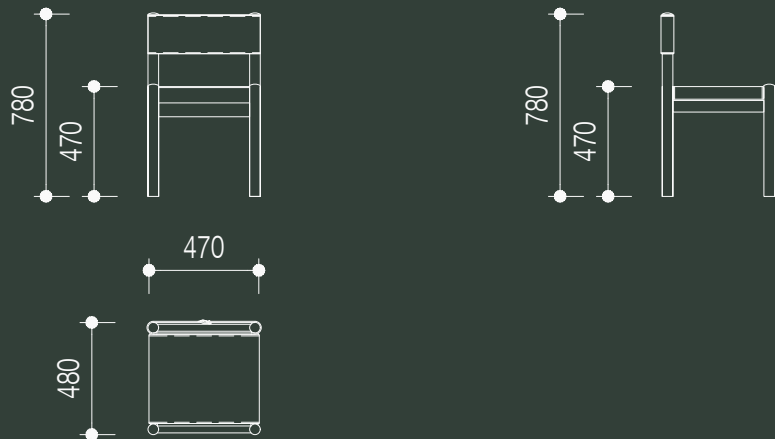

2 - carver

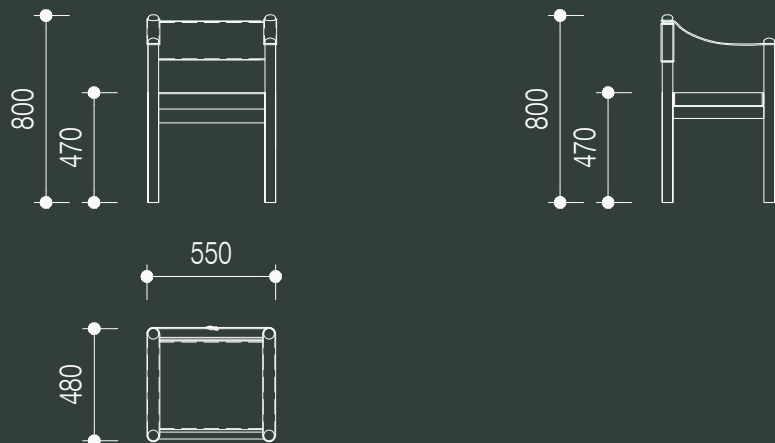

3 - stool

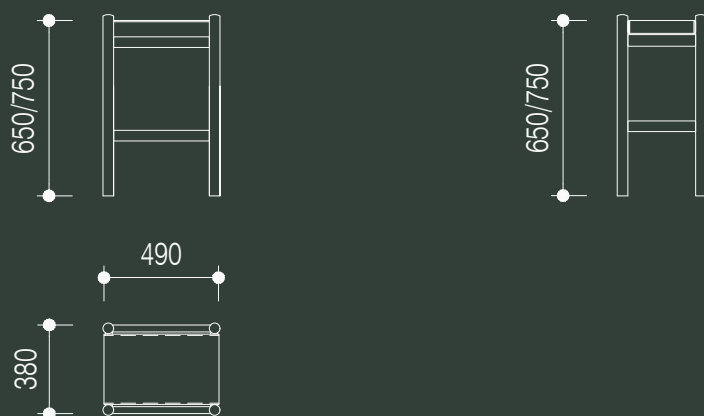

**design registration no**  
chair 202311788

**designer**  
mary featherston

**year designed**  
1972

**1 year structural workmanship warranty with gordon mather industries**  
this warranty does not cover general wear, tear or damage to fabric, leather, stitching, timber or powder-coated finishes once supplied. featherston furniture is designed to hold a weight of 110kg when used correctly. any damage to the structure or joints from excess or uneven weight distribution will not be covered under warranty. armrests are not designed to be sat on and furniture is not designed to be dragged or rocked. warranties will be voided if the product has been disassembled, modified or repaired by any unauthorized party or is damaged in transit or used outside its intended use. featherston products (except for the outdoor ranges) are for internal use only and will not be covered under warranty if damage is a result of environmental or prolonged climatic exposure i.e. rust, direct sun damage, heating or cooling source damage. please care for your featherston products as per the following care instructions for your warranty to be valid

all terms outlined in this document are applicable exclusively to projects and orders that are based in australia. for warranty claims outside australia, please note that a 12 month warranty period will apply, all claims are to be taken up with the international selling agent

to view the full warranty please refer to the link below

<https://graziaandco.com.au/wp-content/uploads/2020/10/GMI-Warranty-and-Care-Instructions.pdf>

<b>craftmanship:</b>	manufactured in australia
<b>materials:</b>	frame- solid american ash, stained as specified seat – vegetable dyed leather buckle – natural brass
<b>lead time:</b>	12-14 weeks. lead times may vary during peak periods
<b>suitability:</b>	indoor use



australian  
made



1 year  
warranty

**grazia&co**<sup>®</sup>

### upholstery & leather

fabric, vinyl and leather used to upholster our furniture is not included in our warranty however separate warranty claims can be made through your retailer or fabric supplier. an independent leather or fabric report can be obtained to determine fault. we recommend regular vacuuming or dusting with a soft vacuum brush attachment to remove dirt and dust which can accumulate and damage the surface (a minimum of every 2-3 weeks is advisable). remove spills by blotting with a soft and absorbent colourfast cloth. leathers can be treated with conditioners and cleaners as per their strict instructions using a soft cloth but we do not recommend scrubbing leather with harsh brushes or sponges in any circumstances. to preserve the supple character of leather we recommend a nourishment cream every few months or more frequently for heavy usage. always follow the directions of the product used and test first on a non-visible area of the product. when in contact with oils, sunscreens or moisture on a regular basis we recommend wiping down leather with a soft damp cloth more regularly to avoid residue build up. for heavy traffic commercial areas this may be required several times a week depending on the situation i.e. areas adjacent to pools. the natural salts and oils that occur in human skin can damage surfaces if left uncleaned for lengthy periods. in warm or humid weather wiping can be required weekly, particularly if it has become damp with perspiration. always clean along any creases that have developed and pay close attention to areas that come in contact with skin like headrests, armrests or seat cushions. leather is a natural product with varied characteristics in each hide so you may see growth marks and scars or creases that develop which cannot be removed without destroying the natural beauty and softness of the hides. if a stain persists contact a professional cleaner and do not hand wash, dry clean or use detergents, solvents or abrasive cleaners. deterioration arising from incorrect or inadequate maintenance is not considered a fault.

### timber

our furniture is finished with a beeswax or satin or matt lacquer which may fade or discolour if left in direct sunlight for long periods of time. always avoid hot objects making contact or having close proximity with timber to avoid burning, discolouration or lifting. solid timber can absorb liquids or moisture causing the timber to move, change in form, crack or mold so spillages should be cleaned up as soon as possible. clean regularly with a soft damp cloth to remove dust, do not clean with a dry to avoid abrasion. spray polishes should never be used as they contain silicone which can spoil the surface by building up over time. a small amount of natural movement in the timber is expected as it adapts to its conditions due to variations in humidity and temperature. timber will display different grain patterns, colours and shadings over a piece of furniture as this is the natural beauty of wood. the 'medullary ray' in oak for example is a mark of good quality timber and appears when cross cut across the grain showing growth rings and flecks. these characteristics of timber are not considered faults.



australian  
made



no direct  
sunlight



do not dry  
clean



do not  
machine  
wash



do not iron